

5tTRSGx25-O

REV	CHANGE DESCRIPTION	ECN	DATE	REVISED BY	APPROVED BY
-----	--------------------	-----	------	------------	-------------

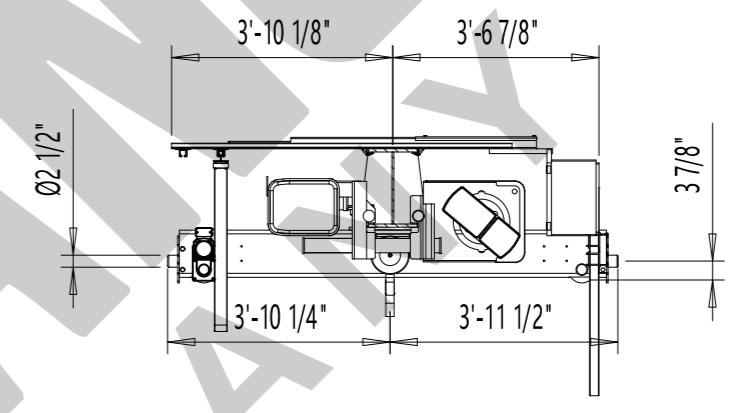
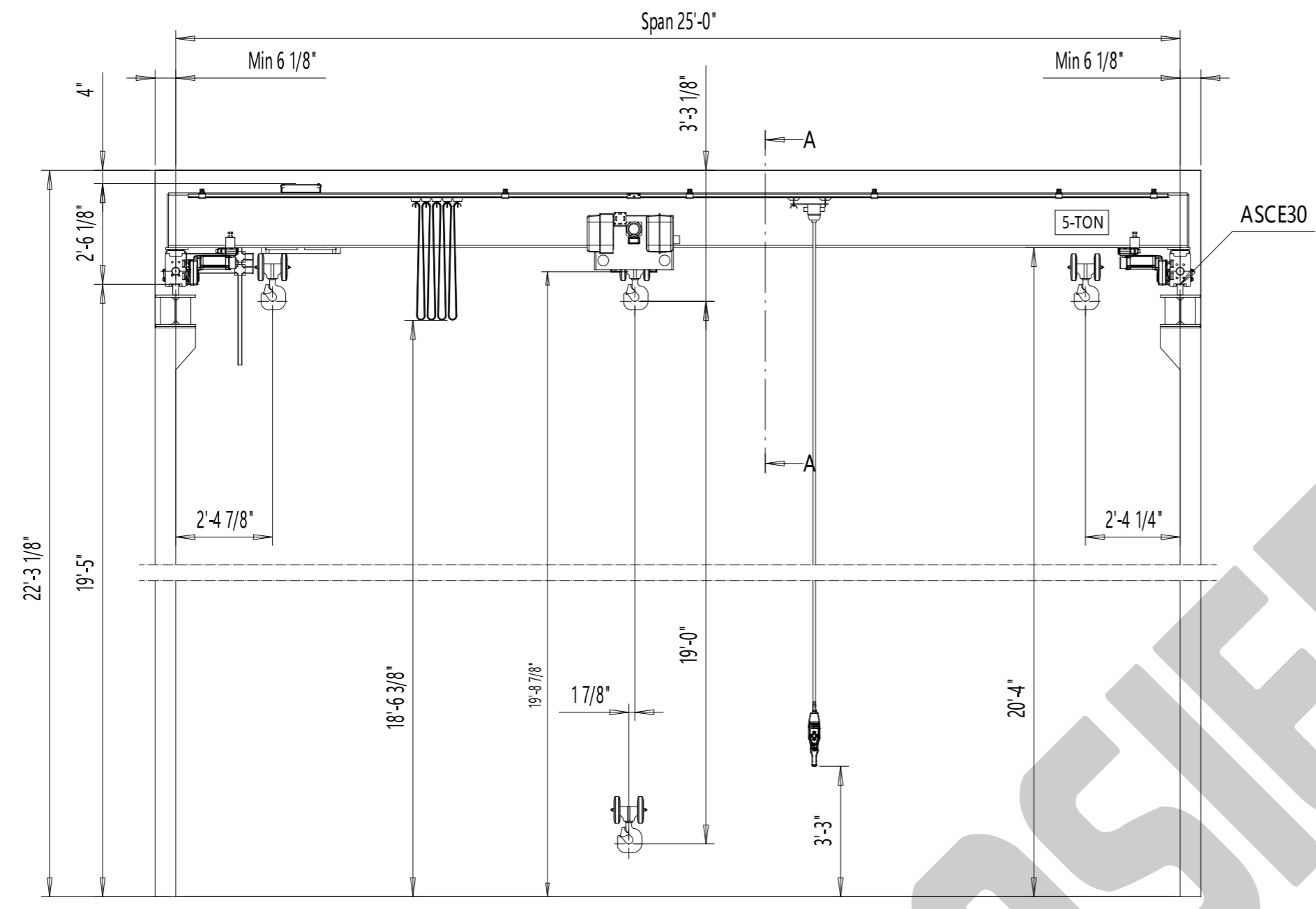

View A-A

SPECIFY NORTH

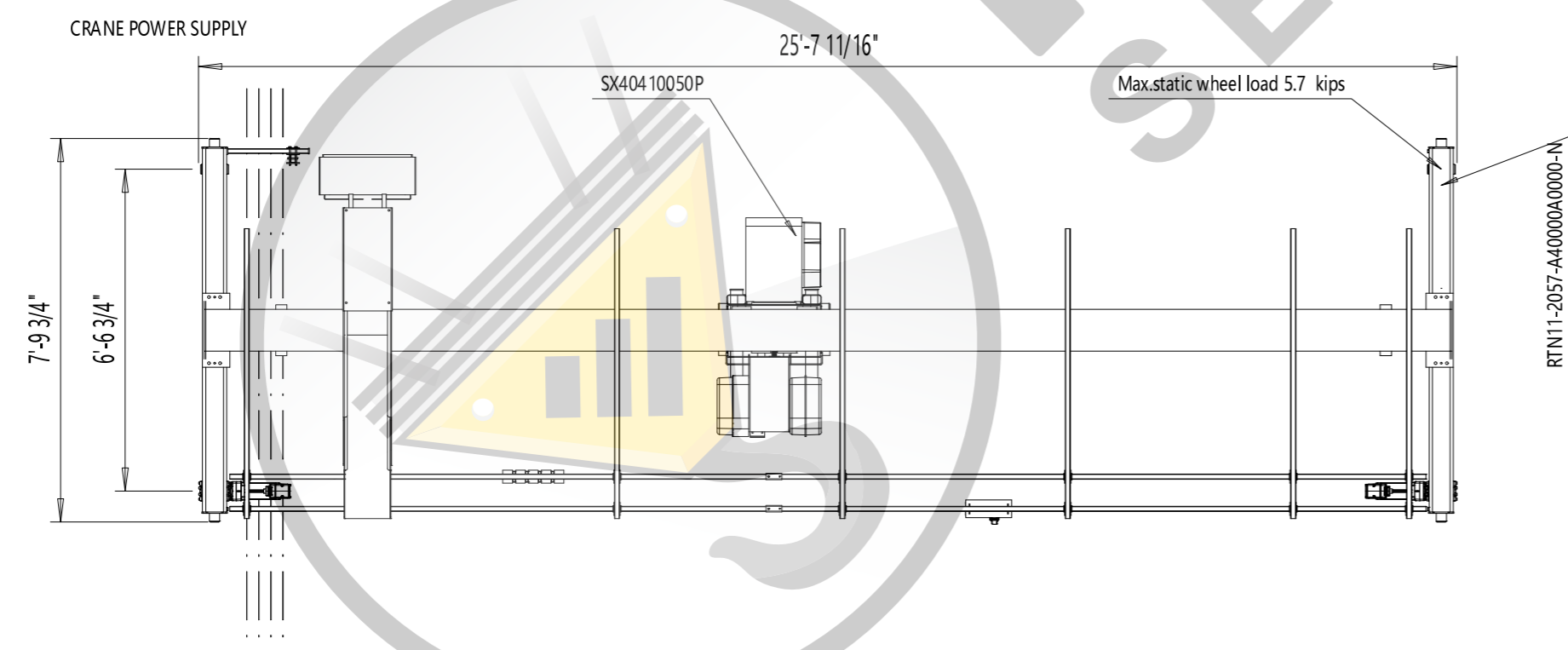
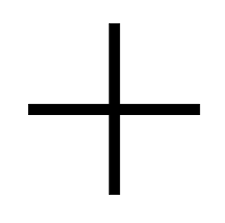

TECHNICAL DATA

SPAN	: 25'-0"
LOAD	: 5-TON
LIFTING HEIGHT	: 19'-0"
HOISTING SPEED	: 20.0/3.2 ft/min 2-speed
TRAVERSING SPEED	: 65 ft/min stepless
TRAVELLING SPEED	: 100 ft/min stepless
WEIGHT OF TROLLEY	: 820 lbs
WEIGHT OF BRIDGE	: 2848 lbs
CRANE CLASSIFICATION	: CMAA Class C
HOIST GROUP	: ISO M5/ Fem 2m
CRANE DRIVE GROUP	: CMAA C
MAIN / CONTROL VOLTAGE	: 460 / 115 V; 60 Hz
SUPPLY POWER	: 8.62 Hp
LENGTH OF RUNWAY	: 0

SURFACE TREATMENT OF CRANE
 BRIDGE COLOR : Safety Yellow
 PAINT : AKRYL/127 µm

CUSTOMER ORGANIZES SAFE
 PLATFORM FOR CRANE SERVICE

Indoor Use crane



ACCEPTED BY:	COMPANY:	DATE:	Design		Date	Dept	DAS / 2.108.9
			QXska5-TON x 25ft HoI:19ft				Vx proj
			5tTRSGx25-O				

This document is the absolute property of R&M. This document must not be copied without the written permission of R&M. The contents thereof must not be disclosed to a third party nor be used for any unauthorized purpose. Contamination will be prosecuted.

5tTRSGx25-O-I

REV	CHANGE DESCRIPTION	ECN	DATE	REVISED BY	APPROVED BY
-----	--------------------	-----	------	------------	-------------

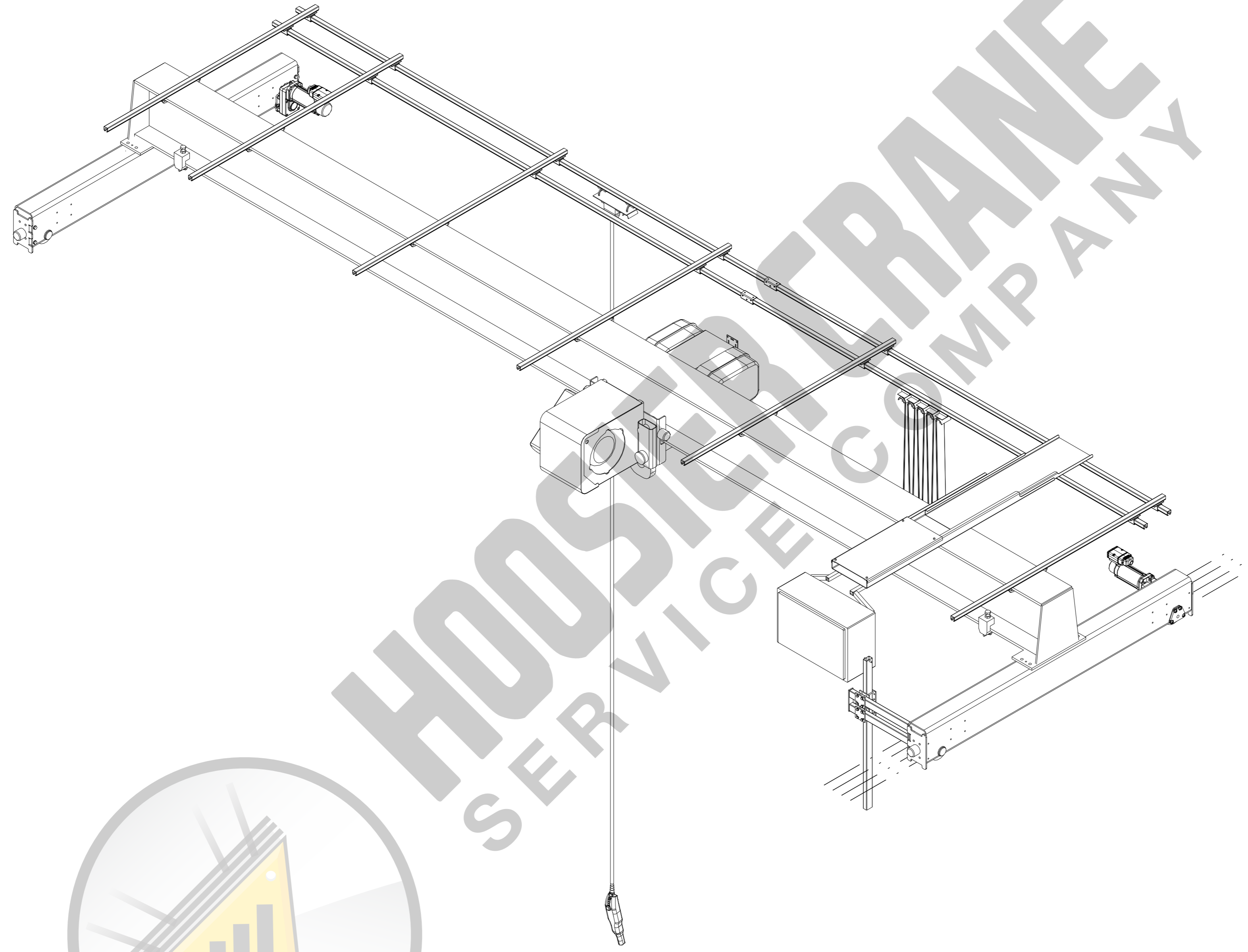

This document is the absolute property of R&M. This document must not be copied
 without the written permission of R&M.
 The contents thereof must not be disclosed to a third party nor be used for any unauthorized
 purpose. Contamination will be prosecuted.



Pos	Amount	Description	Specification
ACCEPTED BY:		Design	Date
COMPANY:		Dept	
DATE:		Vx proj	
		QXska5-TON x 25ft HoI:19ft	
		1:40	
		M-film	
		Issue	
		5tTRSGx25-O-I	