

DETAIL - CRANE COLLECTOR ARM OPTION

$4 \frac{1}{16}'' + (1/2 \times \text{FLANGE WIDTH})$
WITHOUT COLLECTOR ARM

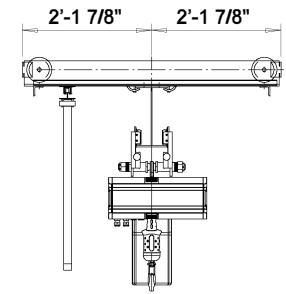

VIEW A-A

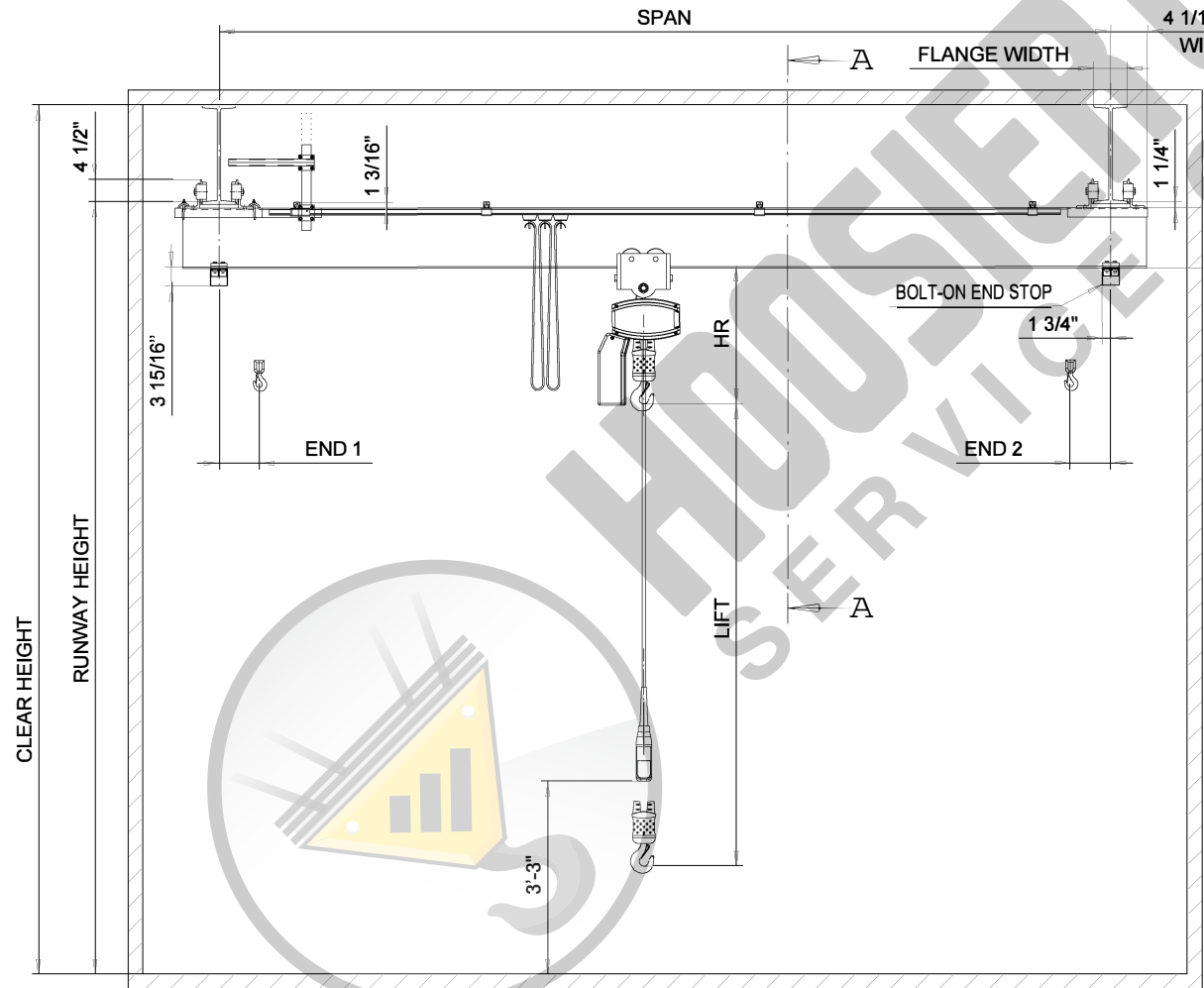

Capacity	Hoist	HR	END 1	END 2
1/2 T	LK05 C - 1 fall	20"	5 7/8"	5 7/8"
1 T	LK10 C - 1 fall	23"	6 11/16"	6 11/16"
2 T	LK10 C - 2 fall	28"	7 9/16"	7 9/16"



QLP SGUR PUSH CRANE