

20tTRDGx25-O

REV	CHANGE DESCRIPTION	ECN	DATE	REVISED BY	APPROVED BY
-----	--------------------	-----	------	------------	-------------

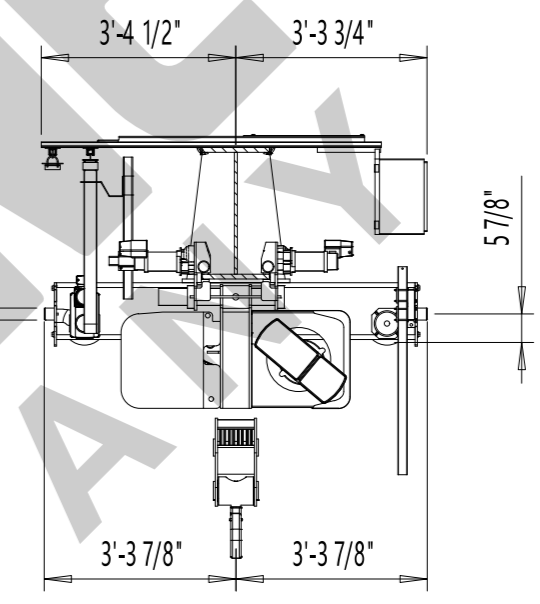
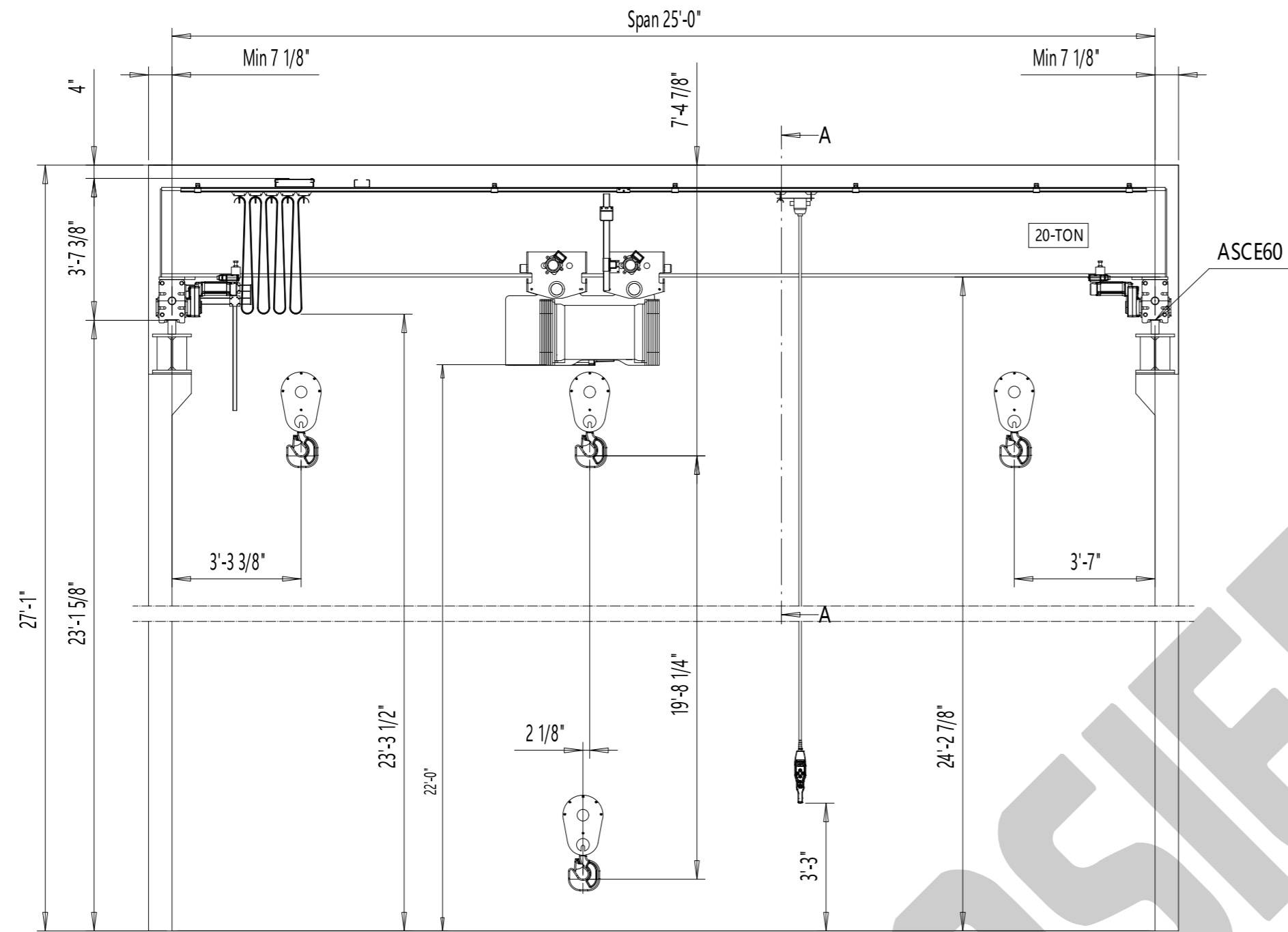

View A-A

SPECIFY NORTH

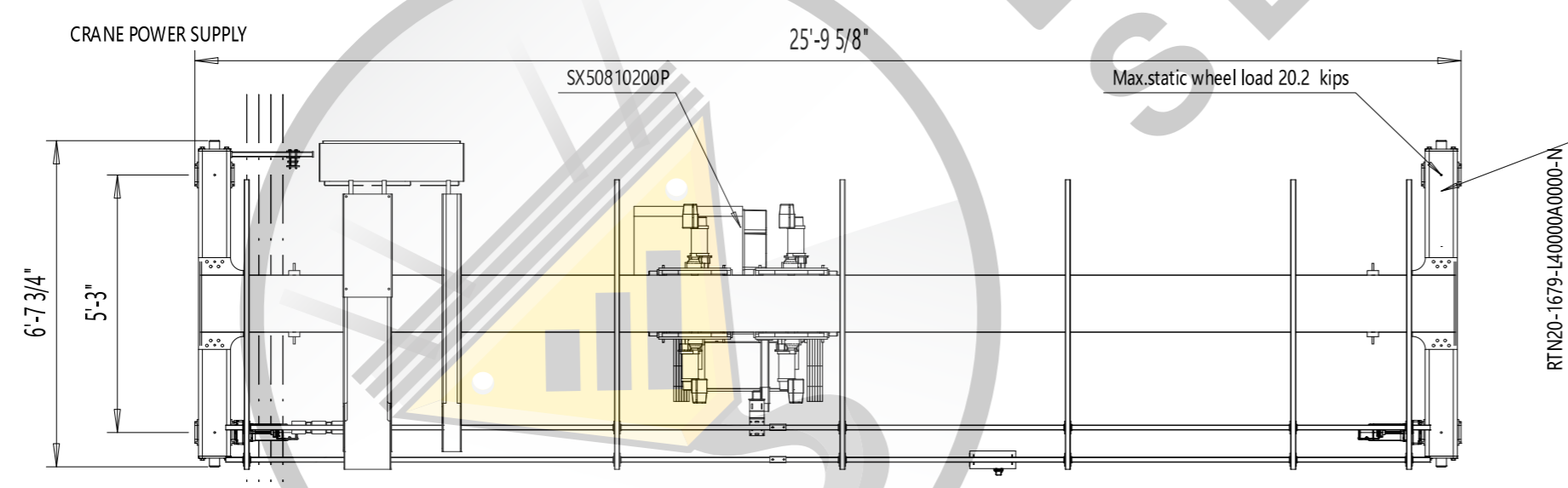
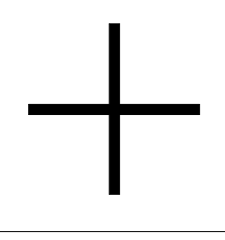

TECHNICAL DATA

SPAN	: 25'-0"
LOAD	: 20-TON
LIFTING HEIGHT	: 19'-8 1/4"
HOISTING SPEED	: 10.0/1.6 ft/min 2-speed
TRAVERSING SPEED	: 65 ft/min stepless
TRAVELLING SPEED	: 100 ft/min stepless
WEIGHT OF TROLLEY	: 2400 lbs
WEIGHT OF BRIDGE	: 5296 lbs
CRANE CLASSIFICATION	: CMAA Class C
HOIST GROUP	: ISO M4/ Fem 1Am
CRANE DRIVE GROUP	: CMAA C
MAIN / CONTROL VOLTAGE	: 460 / 115 V; 60 Hz
SUPPLY POWER	: 18.06 Hp
LENGTH OF RUNWAY	: 0

SURFACE TREATMENT OF CRANE
 BRIDGE COLOR : Safety Yellow
 PAINT : AKRYL/127 µm

CUSTOMER ORGANIZES SAFE
 PLATFORM FOR CRANE SERVICE

Indoor Use crane



Pos	Amount	Description	Specification
ACCEPTED BY:		Design	Date
COMPANY:		Dept	Vx proj
DATE:		QXS20-TON x 25ft Ho:19.69ft	
		1:40 M-film	
		20tTRDGx25-O	
		Issue	

This document is the absolute property of R&M. This document must not be copied
 without the written permission of R&M.
 The contents thereof must not be disclosed to a third party nor be used for any unauthorized
 purpose. Contamination will be prosecuted.

20tTRDGx25-O-I

REV	CHANGE DESCRIPTION	ECN	DATE	REVISED BY	APPROVED BY
-----	--------------------	-----	------	------------	-------------

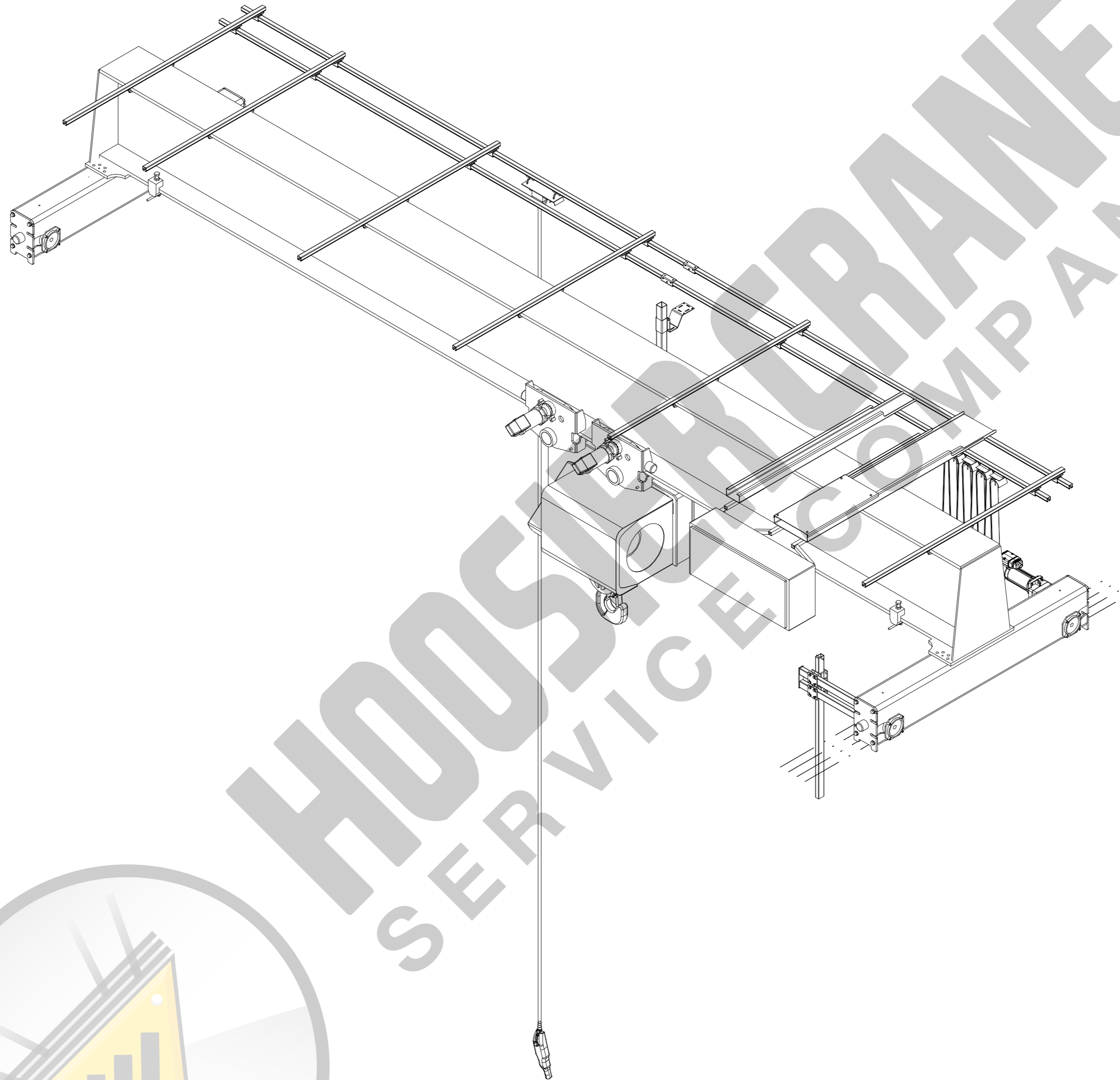

HOOSIER SERVICE COMPANY
 R&M BRAND

This document is the absolute property of R&M. This document must not be copied without the written permission of R&M. The contents thereof must not be disclosed to a third party nor be used for any unauthorized purpose. Contamination will be prosecuted.



Pos	Amount	Description	Specification
ACCEPTED BY:		Design	Date
COMPANY:		Dept	Vx proj
DATE:		QXS20-TON x 25ft Ho:19.69ft	
		1:40 M-film	
		20tTRDGx25-O-I	
		Issue	

1 2 3 4 5 6 7 8 9 10 11 12

A
B
C
D
E
F
G
H

A
B
C
D
E
F
G
H

1 2 3 4 5 6 7 8 9 10 11 12