

DOUBLE GIRDER, MEDIUM, 4 PART SINGLE

Hoist type:

SX2 041..D0

SX3 041..D0

US-60Hz

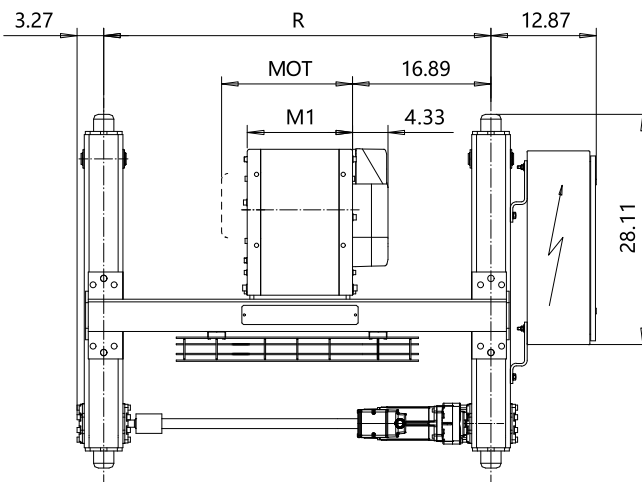
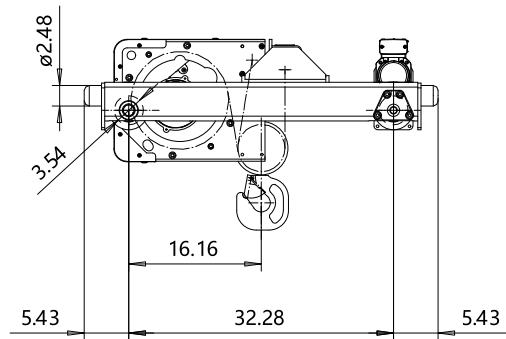
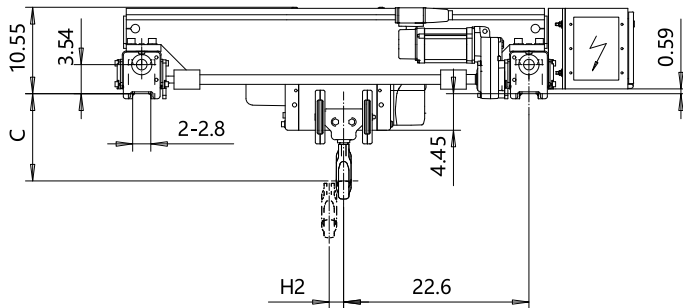

Motor	P1	P2	P3	A3	S3
MOT (in)	15.2	17.6	18.7	17.6	20.7
Weight (lb)	46	68	77	71	62

HOL (ft-in)	Length code	M1 (inch)	H2 (inch)	min R (ft-in)	Approx. Weight (lb)
19'-8"	A	12.8	1.77	3'-11 1/4"	496
31'-2"	C	18	2.84	3'-11 1/4"	518

Headroom - C dimension	
Standard	12 1/4"
with HS22 Hook operated limit switch	16 3/16"

Load (ton)	Class ASME
1 1/2	H4 +
2	H4
2 1/2	H4 +
3	H4

Note: minR is minimum rail gauge when second brake is supplied
 Standard rail gauges are 3'-11 1/4", 4'-7 1/8", 5'-6 7/8", and 6'-6 3/4"
 Approx. weight calculated with P1 motor and Min R.

This document is the absolute property of R&M Materials Handling, Inc. This document must not be copied without the written permission of R&M Materials Handling, Inc. The contents thereof must not be disclosed to a third party nor be used for any unauthorized purpose. Contravention will be prosecuted.

Design	Chd	Appd	Ref Drawing	QA-M-04
Date	TROLLEY; DOUBLE GIRDER			1:10 Fo/Mir
SLEQMECE Owner Dept	MEDIUM, 4 ROPE FALLS			
R&M MATERIALS HANDLING INC.	R&M MATERIALS HANDLING, INC. HOIST & CRANE PRODUCTS SPRINGFIELD, OHIO			Issue 8
D002081-A				