

Dynasafe[®]

HF 32 Universal Load Cell

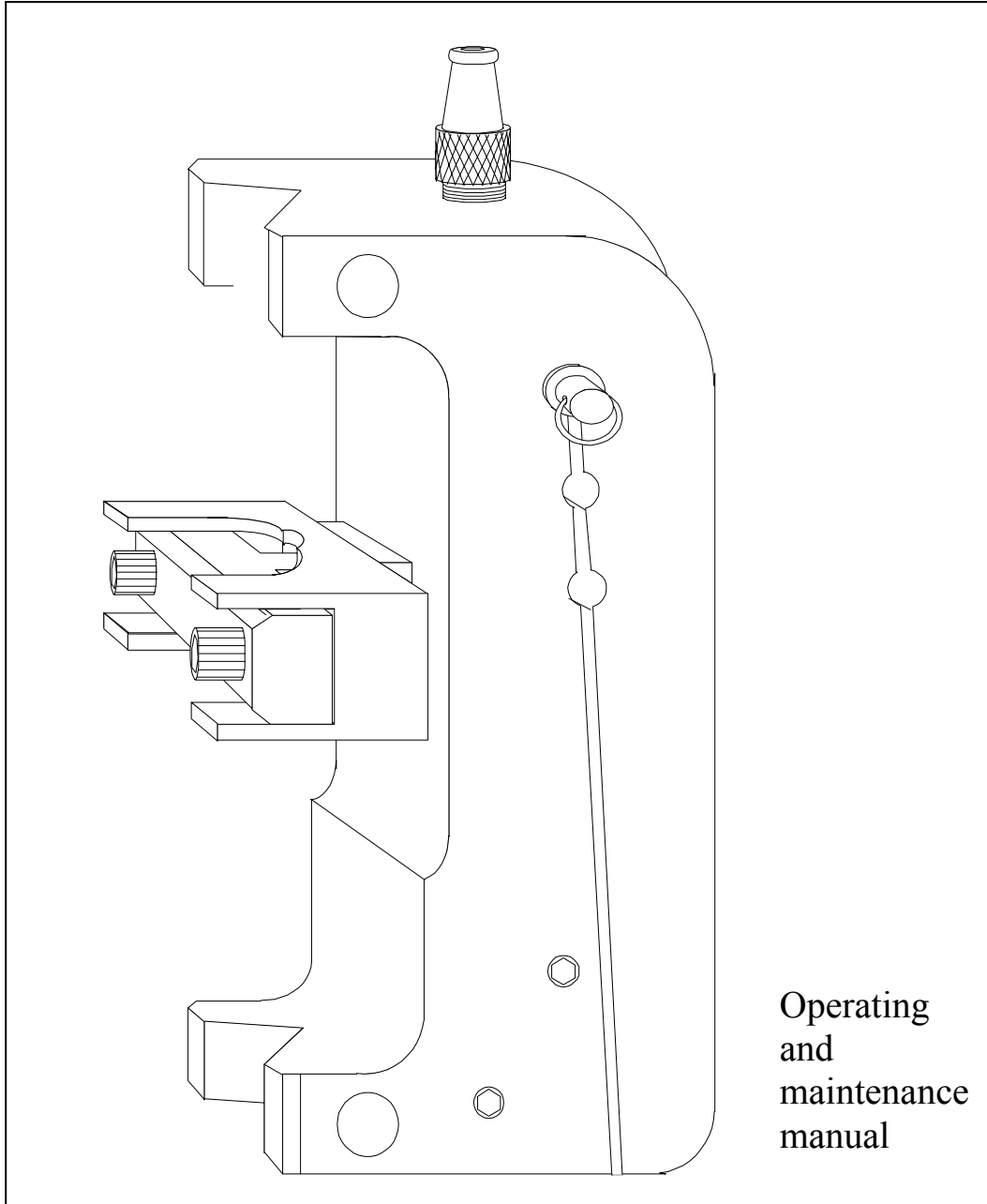

Printed in the U.S.

CM - 10/04



MAIN OFFICE: 110 SHAWMUT ROAD, P.O. BOX 188, CANTON, MASSACHUSETTS 02021

TEL: (781) 401 - 3288 • FAX: (781) 828 - 3642

315 CLOVERLEAF DRIVE, UNIT E, BALDWIN PARK, CA 91706

TEL: (626) 937 - 6727 • FAX: (626) 937 - 6730

INTERNET: www.tractel.com

E-MAIL: griphoist@worldnet.att.net

TABLE OF CONTENTS

General Warnings.....	2	
Installation Overview.....	3	
Unit Installation		
HF32/1.....	4	• Load Cell Installation.....4-6
HF32/2.....	5	
HF32/3.....	6	• Wiring & Monitor Installation.....7-10
Operation and Adjustment		
HF32/A.....	7	
HF32/B.....	8	
Related Products.....	11	

Nomenclature: HF32/Size/Switch
ex./ HF32/1/A

⚠ GENERAL WARNINGS ⚠

1. Reading and fully understanding the technical data sheets relating to all related equipment is essential for the safe use of this information that you have received. All the technical data sheets are available on request from TRACTEL
2. It is essential for the safe and correct operation of this unit to read and fully understand this manual prior to installation and operation. This manual should be made available to every operator and user. Extra copies of this manual are available from TRACTEL on request.
3. The installation and operation of DYNASAFE equipment should only be carried out in accordance with the appropriate health and safety at work regulations.
4. Never apply a load or effort greater than the working load limit on any associated equipment. Never use the DYNASAFE for an operation for which it is not intended.
5. TRACTEL declines any responsibility for the consequences of dismantling or altering the device or associated equipment by any unauthorized person.
6. This DYNASAFE equipment must not be used in explosive atmospheres. For these applications, contact TRACTEL for information on the HF32/Eex series.
7. DYNASAFE equipment must only be used in a system designed for lifting people after ensuring that the appropriate factors of safety have been used in accordance with the current regulations.
8. Prior to the use of DYNASAFE equipment with complementary equipment relaying the signals to an operating system, the user or installer of this system should carry out a specific risk analysis of the operating functions. The appropriate measures should be taken to alleviate any risks identified.



INSTALLATION OVERVIEW OF THE HF32 LOAD CELL

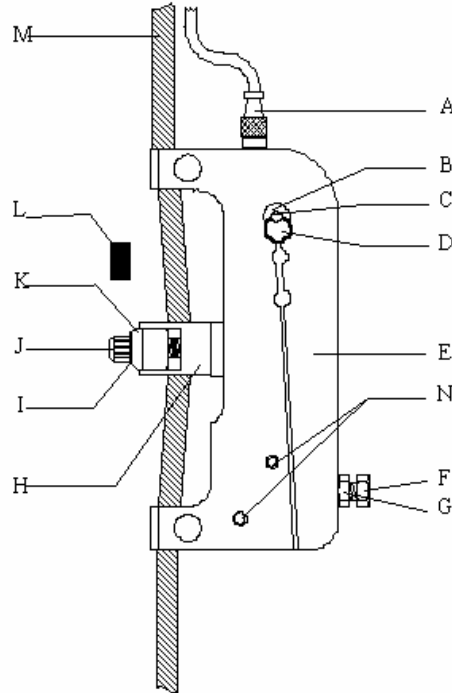

Components of the load cell:

A. 6' (2m) connecting cable	F. Trip point tare screw	K. Fixing bracket plate
B. Flat washer	G. Locking nut	L. Rubber compression pad
C. Adjusting axle pin	H. Central fixing bracket	M. Lifting wire rope
D. Locking ring	I. Safety washer	N. Switch fixing screw
E. Load cell body	J. Tightening screw	(DO NOT TOUCH)

Procedure for installing the load cell:

**Ensure the hook of the lifting system is free of any load

- Position the adjusting pin as a function of the load range and wire rope diameter. (See pgs. 4-6)
- Remove the fixing bracket plate (K) .
- Position the load cell on the wire rope near the dead end / fixed point. The connecting cable should be on the top of the device.
- Replace the tightening bracket (K), making sure that it is correctly positioned depending on the diameter of the wire rope (See pgs. 4-6)
- Adjust the tightening screws (J) symmetrically (± 3.5 ft lbs.) to ensure that there is no risk of moving the load cell out of line with the wire rope. Excessive tightening may break the bracket.
- Operate the lifting system to the upper limit switch and check that the sheaving or bottom block does not contact the load cell. If this happens, adjust the upper limit switch so that there is an appropriate distance between the two. Also, check that when the bottom block is in the upmost position, the load cell is not in contact with the overhead crane.
- Wire the connecting cable from the load cell to the control box. Ensure that the cable is secured.



INSTALLATION OF THE HF32/1 LOAD CELL

The adjusting pin placement depends on the wire rope diameter.

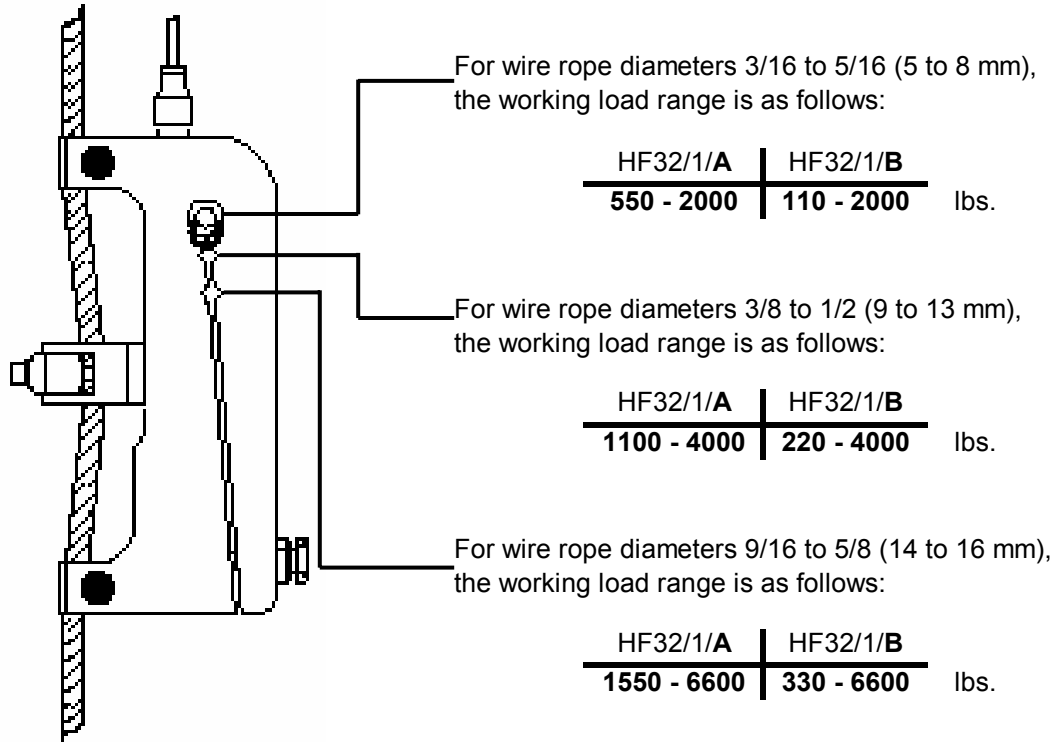

Positioning of the tightening bracket depends on the diameter of the wire rope.

3/16 to 5/16 (5 to 8mm) wire rope
without the rubber compression pad,
using the M6 X 25 mm screws supplied

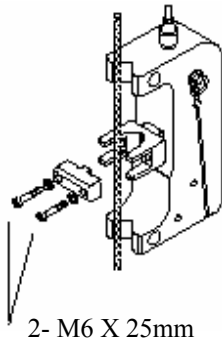

3/8 to 5/8 (9 to 16mm) wire rope
with the rubber compression pad,
using the M6 X 30 mm screws supplied

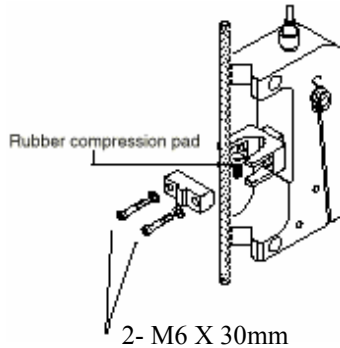

MAIN OFFICE: 110 SHAWMUT ROAD, P.O. BOX 188, CANTON, MASSACHUSETTS 02021
 TEL: (781) 401 - 3288 • FAX: (781) 828 - 3642
 315 CLOVERLEAF DRIVE, UNIT E, BALDWIN PARK, CA 91706
 TEL: (626) 937 - 6727 • FAX: (626) 937 - 6730

INSTALLATION OF THE HF32/2 LOAD CELL

The adjusting pin placement depends on the wire rope diameter.

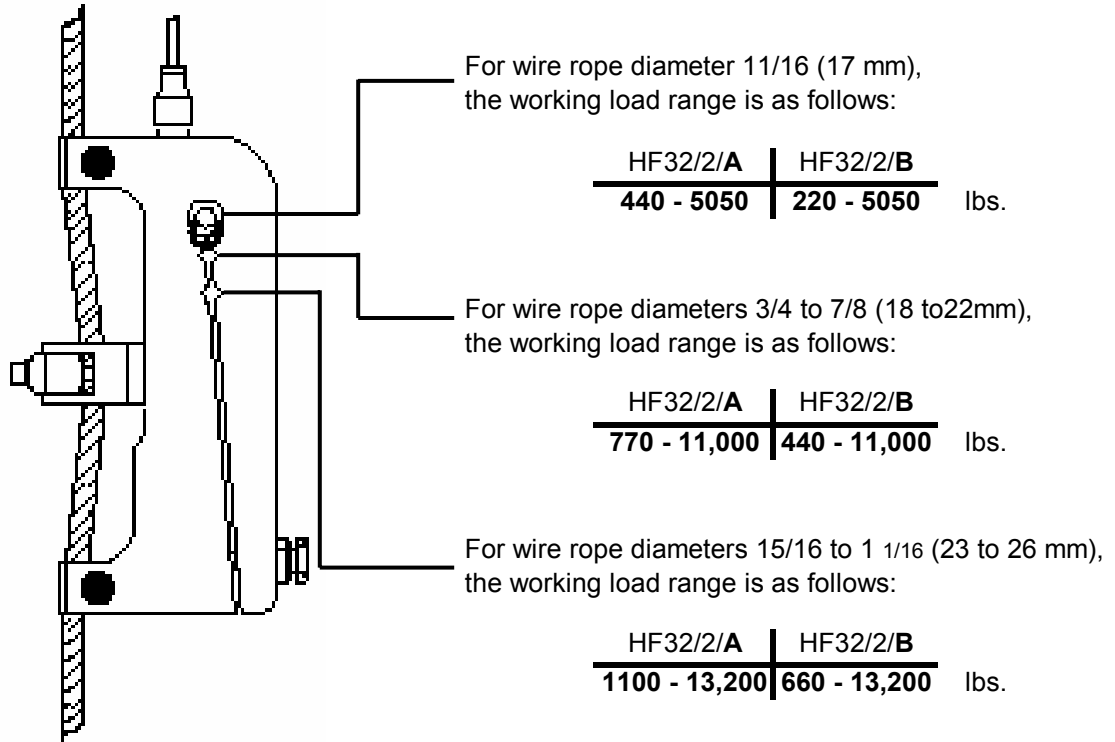

Positioning of the tightening bracket depends on the diameter of the wire rope.

11/16 (17mm) wire rope
without the rubber compression pad,
using the M8 X 40 mm screws supplied

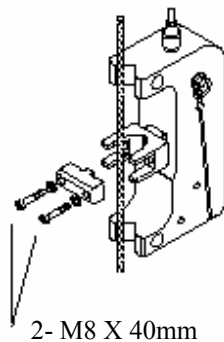

3/4 to 1 1/16 (18 to 26mm) wire rope
with the rubber compression pad,
using the M8 X 50 mm screws supplied

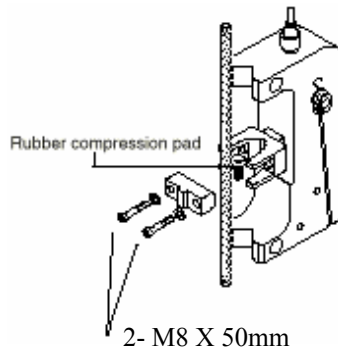

MAIN OFFICE: 110 SHAWMUT ROAD, P.O. BOX 188, CANTON, MASSACHUSETTS 02021
 TEL: (781) 401 - 3288 • FAX: (781) 828 - 3642
 315 CLOVERLEAF DRIVE, UNIT E, BALDWIN PARK, CA 91706
 TEL: (626) 937 - 6727 • FAX: (626) 937 - 6730

INSTALLATION OF THE HF32/3 LOAD CELL

The adjusting pin placement depends on the load range.

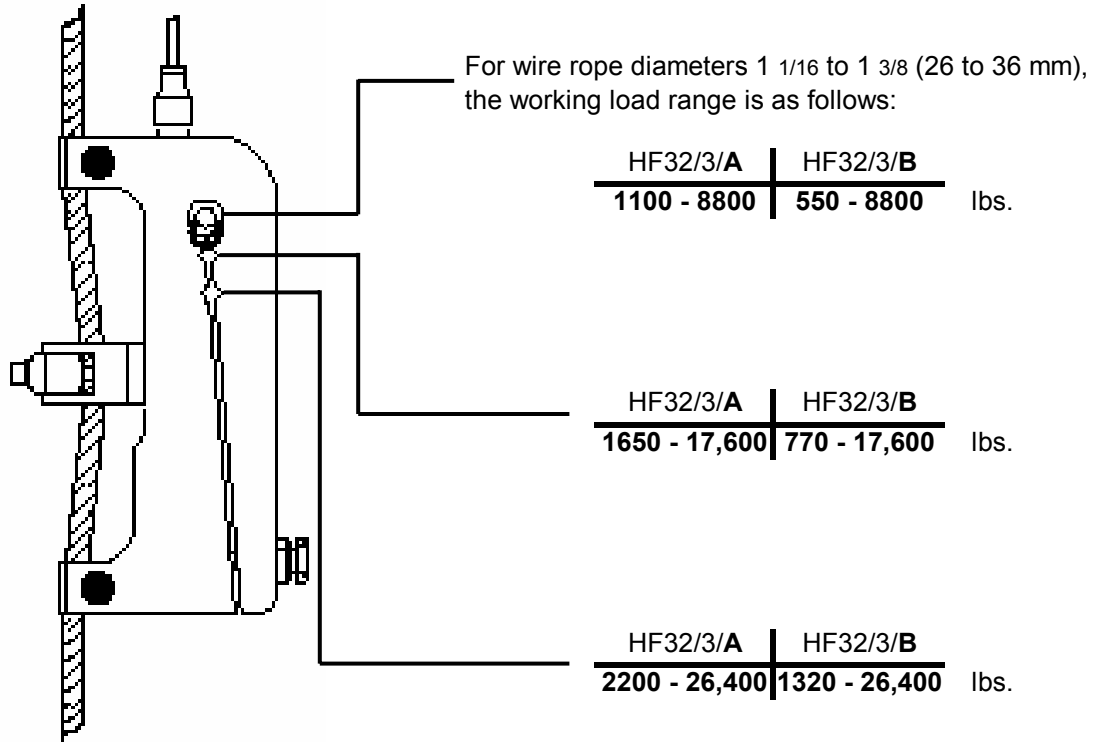

Positioning of the tightening bracket.

1 1/16 to 1 3/8 (26 to 36mm) wire rope
without the rubber compression pad,
using the M12 X 80 mm screws supplied

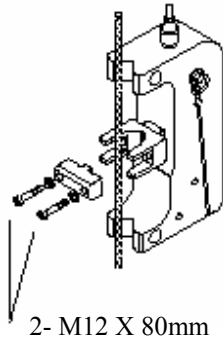

MAIN OFFICE: 110 SHAWMUT ROAD, P.O. BOX 188, CANTON, MASSACHUSETTS 02021
 TEL: (781) 401 - 3288 • FAX: (781) 828 - 3642
 315 CLOVERLEAF DRIVE, UNIT E, BALDWIN PARK, CA 91706
 TEL: (626) 937 - 6727 • FAX: (626) 937 - 6730

OPERATION AND ADJUSTMENT OF THE HF32/A LOAD CELL

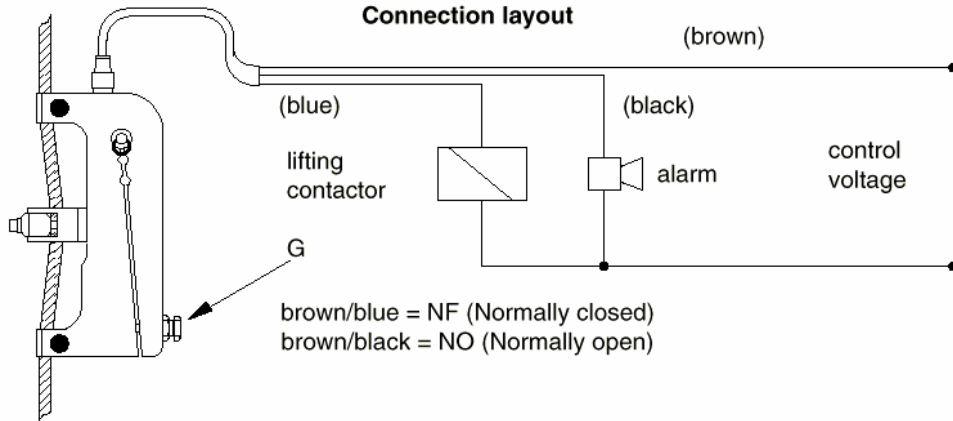

The switching power is 4 A, 220 Vac (0.3 A, 250 Vac). It is therefore possible to connect in series within the upper limit switch circuit.

Adjustment of the safety trip point

Essential conditions:

- The load cell must be correctly installed and wired.
- The hook of the lifting system should be free of any load.

Equipment required:

- A load (P_m) equivalent to 100% of the working load limit of the lifting system.
- An additional load equivalent to 10% of P_m

	ACTION	EXPLANATION
1	Lift the two loads ($P_m + 10\%$ of P_m) By $\pm 4''$	The additional 10% load represents the overload value permitted. *If an overload situation is detected in the wire rope (without lifting the loads) the pre-adjustment of the load cell in the factory is too low for your lifting system. Solution: release the tightening screw (G – see Fig. 4) one turn at a time and restart at the beginning of step 1.
2	Adjust the safety point	Use the tightening screw (G) WARNING – Incorrect adjustment may damage the circuit-breaker <ul style="list-style-type: none"> • Do not forget to tighten the locking nut (F). • The switch is a normally closed (NC) contact, requiring the opening of the switch to indicate an overload situation. • Clockwise reduces the value of the trip point. • Counterclockwise increases the value of the trip point.



OPERATION AND ADJUSTMENT OF THE HF32/B LOAD CELL

Installation and connection of the HF85 monitor

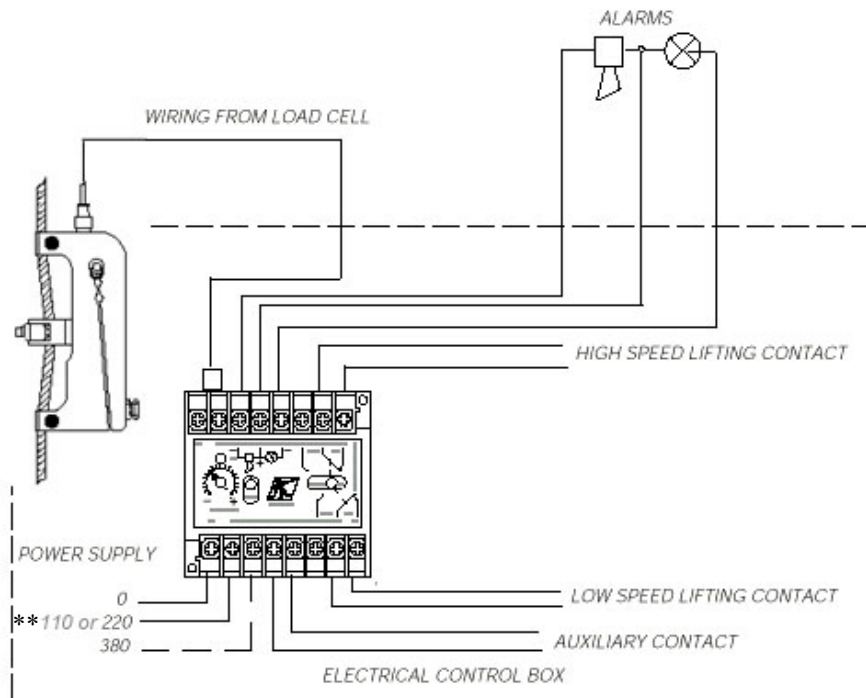

The switching power is 25 mA 24 Vac or 2 mA 15 Vdc. It is essential to check the compatibility in cases where the HF 85 is not used.

Procedure for installation and connection:

- Mount the HF 85 monitor to the “DIN” rail in the electrical control box containing the lifting controls.
- Wire the high speed lifting contactor coil in series between terminals 07 & 08.
- Wire the low speed contactor coil in series between terminals 15 & 16.
- Wire the electronic siren, HF90/1, to terminals 03 & 04, taking care to observe the correct polarity. The alarm function automatically deactivates after 15 seconds.
- Wire the electronic strobe, HF90/2, to terminals 04 & 05. This light remains active throughout an overload condition.
- Connect the load cell to the monitor:
 - White wire → Terminal 1
 - Blue wire → Terminal 2 (non-polarized)
- Connect the power supply to the monitor:
 - 110 or 220 (depending on model) to terminals 9 & 10
 - 380 to terminals 9 & 11

Note: Eventually, connect terminals 12 & 13 to a normally open (NO), potential free contactor on the high and low speed lowering contactor to eliminate the possibility of detecting an overload condition and therefore trigger the alarms during lowering. The dynamic effects in the dead end of the wire rope are greater on lowering than on lifting.



WARNING

** The monitor is designed for either 110 or 220 Vac power, **not both**. Refer to your model before installation. Connecting the monitor to an incorrect power source may cause permanent damage to the equipment.



OPERATION & ADJUSTMENT OF THE HF32/B EQUIPMENT (HF 85)

Adjustment of the safety trip point

- Essential conditions:
- The load cell and the monitor should be correctly mounted and wired.
 - The hook of the lifting system should be free of any load
 - The test operation should have been successfully carried out.

- Equipment required:
- A load (P_m) equivalent to 100% of the working load limit of the lifting system.
 - An additional load equivalent to 10% of P_m

	Actions	Explanation
1	Lift the two loads (100% + 10% of P_m) by +/- 4"	The additional 10% represents the permitted overload value Should an overload condition be detected on the wire rope (without lifting the load) it indicates that the setting of the load cell (preset in the factory) is too low compared to the current loads. Solution: Release the tare screw by one turn at a time and restart at the beginning of step 1.
2	Adjust the safety trip point	Use the tare screw Allen key The microswitch is normally closed (NC) so that when it opens it sets off the overload condition Clockwise reduces the value of the trip point. Counterclockwise increases the value of the trip point.
3	Lower the loads	
4	Remove the additional load (10% of P_m)	
5	Lift the load P_m using low speed lifting	No overload condition should be detected. However, should the dynamic effects create an overload condition, see step 7.
6	Lift the load P_m using high speed lifting	No overload condition should be detected. However, should the dynamic effects create an overload condition, see step 7.
7	If necessary – Lift the load P_m using the potentiometer <EFF.DYN> filter	Under certain conditions, the dynamic effects may create an overload condition which will set off the safety system. The potentiometer on the front of the monitor (HF 85) acts as a filter for this phenomenon by using an average sampling value. The potentiometer <EFF.DYN> has an adjustment range of 0(-) to 3(+) seconds.



MAIN OFFICE: 110 SHAWMUT ROAD, P.O. BOX 188, CANTON, MASSACHUSETTS 02021
 TEL: (781) 401 – 3288 • FAX: (781) 828 - 3642
 315 CLOVERLEAF DRIVE, UNIT E, BALDWIN PARK, CA 91706
 TEL: (626) 937 – 6727 • FAX: (626) 937 – 6730

OPERATION & ADJUSTMENT OF THE HF32/B EQUIPMENT (HF 85)

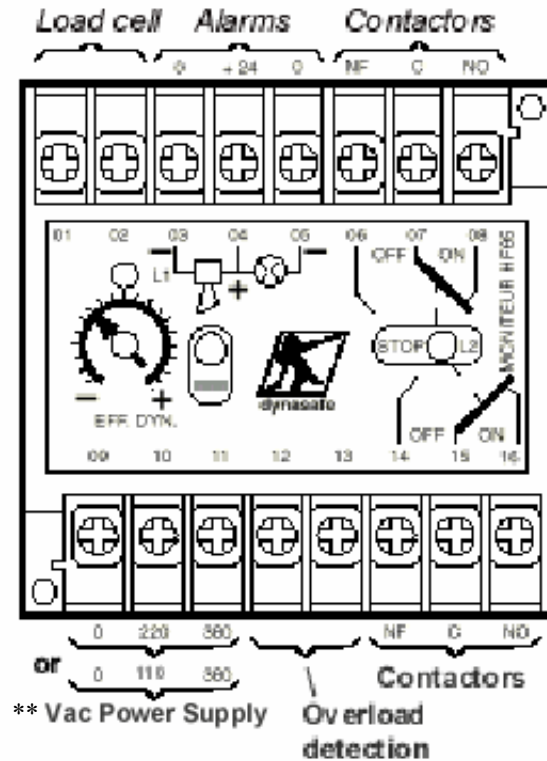

Test function

When the load cell has been fitted and the various connections have been made to the monitor, there is a test procedure to check the correct operation of the installation.

- ◆ Check that the hook of the lifting system is free of any load.
- ◆ Press the test button on the front of the monitor. (This button has the effect of simulating an overload condition).
- ◆ Once the test button has been pressed, the LED (L1) should light up while the LED (L2) will light up when the dynamic effect of the value of the trip point has been reached.
- ◆ When the LED (L2) is lit, the contactors of the monitor will be OFF (overload condition) and the auxiliary functions (siren and strobe) should operate.
- ◆ When the test button is release, it takes 5 seconds for the contactors of the monitor to reset themselves to the ON position.



WARNING ** The monitor is designed for either 110 or 220 Vac power, **not both**. Refer to your model before installation. Connecting the monitor to an incorrect power source may cause permanent damage to the equipment.



Other dynasafe products

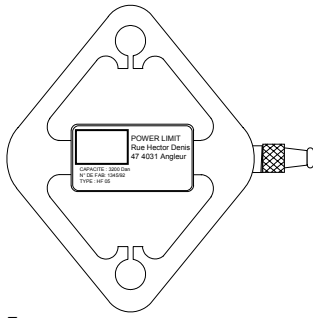

HF05
Mechanical In-Line
Load Cell

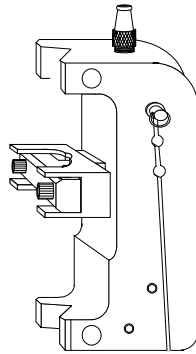

HF32
Mechanical On-Line
Load Cell

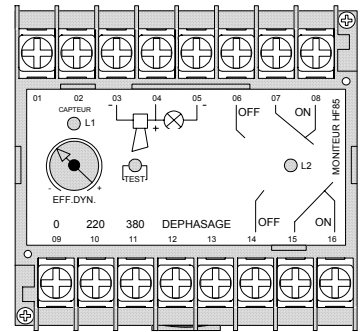

HF85
Mechanical
Load Monitor

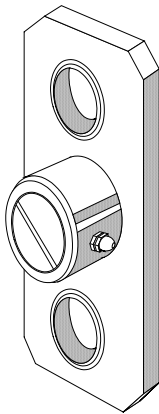

HF10
Electronic In-Line
Load Cell

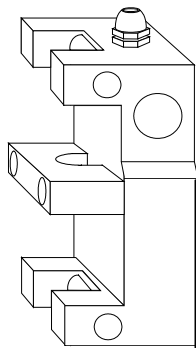

HF35
Electronic On-Line
Load Cell

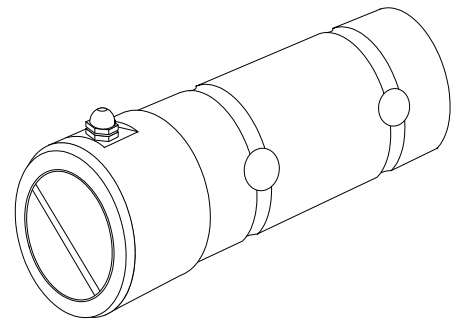

HF50
Electronic Dynamometric Axle
Load Monitor

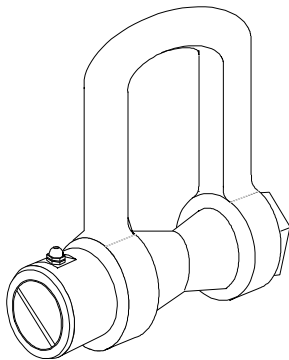

HF55
Electronic Dynamometric Shackle
Load Cell

HF80
Electronic
Load Monitor

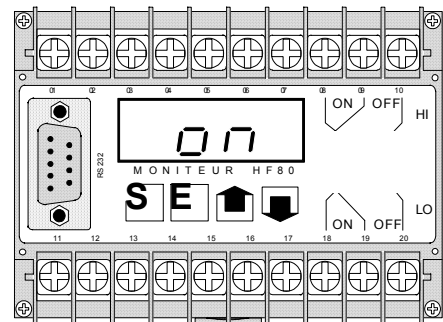

MAIN OFFICE: 110 SHAWMUT ROAD, P.O. BOX 188, CANTON, MASSACHUSETTS 02021
 TEL: (781) 401 - 3288 • FAX: (781) 828 - 3642
 315 CLOVERLEAF DRIVE, UNIT E, BALDWIN PARK, CA 91706
 TEL: (626) 937 - 6727 • FAX: (626) 937 - 6730