



## F24-6D

6 button two-step system that comes with 2 transmitters and 1 receiver with a control voltage of 110/220 V AC or 12-24 V AC / DC.

### Also Available

- F21-6S
- F21-6S-2TX
- F21-6S-DC
- F21-6S-DC-2TX
- F24-6S
- F24-8S
- F24-8D
- F24-10S
- F24-10D
- F24-J

### Legend

1. S = single step
2. D = dual step
3. 2TX = 2 transmitters
4. DC = 12-24 V AC/DC

### General Specifications

**Typical application:** Overhead cranes, dual hoist monorails, etc...

**Operating Distance:** 500 feet

**Frequency:** 310 Mhz band

**Frequency generation:** Crystal (plug in)

**Security coding:**

**Environmental rating:** IP 65

**Licensing:** FCC certified, no license needed. FCC identifier LWN9312F24

**Warranty :** 1 year, see manual

**Temperature rating:** -35 deg C to 75 deg C (-31 deg F to 167 deg F)

### Receiver Specifications

**Size:** W 6.5" x D 4.5" x L 10.0"

**Part #:** F24-6D-RX

**Power Supply input:** 110/220 V AC

**Other input voltages:** 12 -24 V AC / DC

**Relay ratings:** 10 amp/250 V AC

**Weight:** 7 lbs.

**Includes:** Pre-cabled.

**Accessories available:**  
 - Horn & Lamp Kit (Part# 24T9001)  
 - External Antenna Kit

### Transmitter Specifications

**Part #:** F24-6D-TX

**Transmitters:** 2 supplied standard

**Size:** W 2.0" x D 2.0" x L 7.25"

**Weight:** 11 ounces

**Material:** Shock resistant, fiber reinforced nylon

**Power source:** 2 AA alkaline batteries

**Battery power indication:** LED

**Buttons:** 6 programmable, 2 step plus start and stop. Rated to 2 million cycles.

**Start key:** Removable

**Stop Button:** Mushroom style

**Includes:** lanyard and 2 AA batteries

### Receiver Mounting

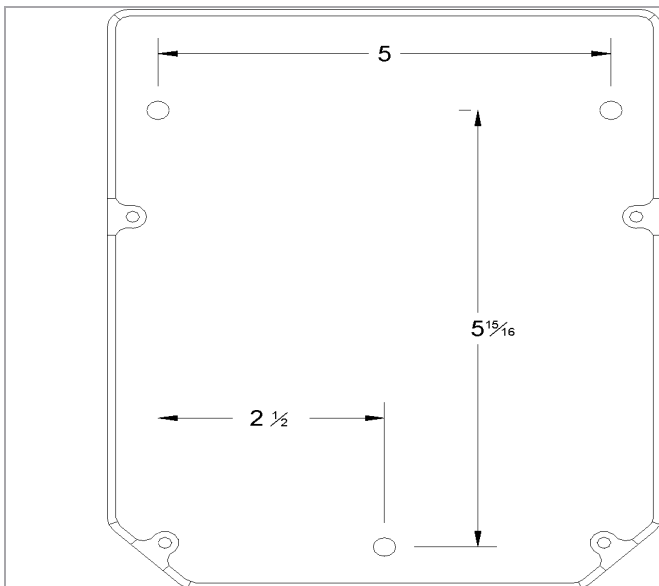

### Receiver Schematic

## F24-6D

