

ITL INTERCONTINENTAL TECHNOLOGIES, LTD.
 HOOSIER CRANE
 Phone:800-509-6131 Fax: 574-523-2916 www.hoosiercrane.com

Also Available

- F24-6S
- F24-6D
- F24-8S
- F24-8D
- F24-10D
- F24-J

Legend

1. S = single step
2. D = dual step
3. 2TX = 2 transmitters
4. DC = 12-24 V AC/DC



F24-10S

10 button single step system that comes with 2 transmitters and 1 receiver with a control voltage of 110/220 V AC or 12/24 V AC / DC

General Specifications

Typical application: Multiple overhead cranes and hoists
Operating Distance: 500+ feet
Frequency: 310 Mhz band
Frequency generation: Crystal (plug in)
Security coding:
Environmental rating: IP 65
Licensing: FCC certified, no license needed. FCC identifier LWN9312F24
Warranty : 1 year, see manual
Temperature rating: -35 deg C to 75 deg C (-31 deg F to 167 deg F)

Receiver Specifications

Size: W 3.37" x D 7.10" x L 7.37"
Part #: F24-10S-RX
Power Supply input: 110/220 V AC
Other input voltages: 12 -24 V AC / DC
Relay ratings: 10 amp/250 V AC
Weight: 7 lbs.
Includes: Pre-cabled.
Accessories available:
 - Horn & Lamp Kit (Part# 24T9001)
 - External Antenna Kit

Transmitter Specifications

Part #: F24-10S-TX
Transmitters: 2 supplied standard
Size: W 2" x D 2" x L 6.2"
Weight: 9 ounces
Material: Shock resistant, fiber reinforced nylon
Power source: 2 AA alkaline batteries
Battery power indication: LED
Buttons: 10 programmable, 1 step plus start and stop. Rated to 2 million cycles.
Start key: Removable
Stop Button: Mushroom style
Includes: lanyard and 2 AA batteries

Receiver Mounting

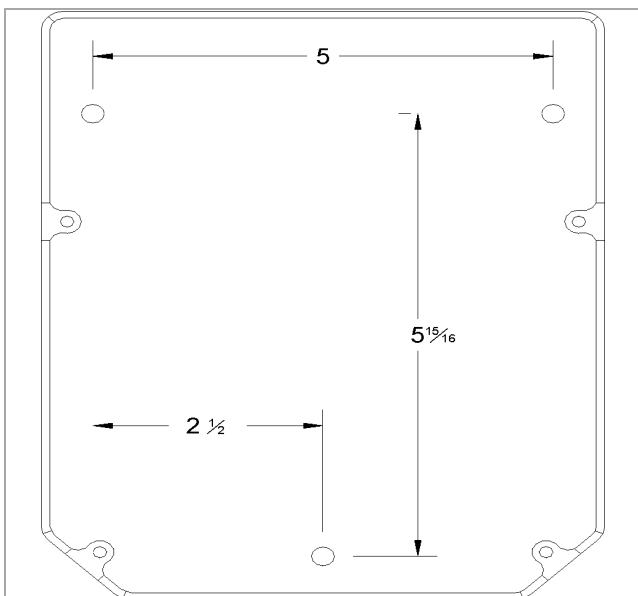

Receiver Schematic

F24•10S

